

Oderstraße

35

30

1.50

DN8-18°

# EG

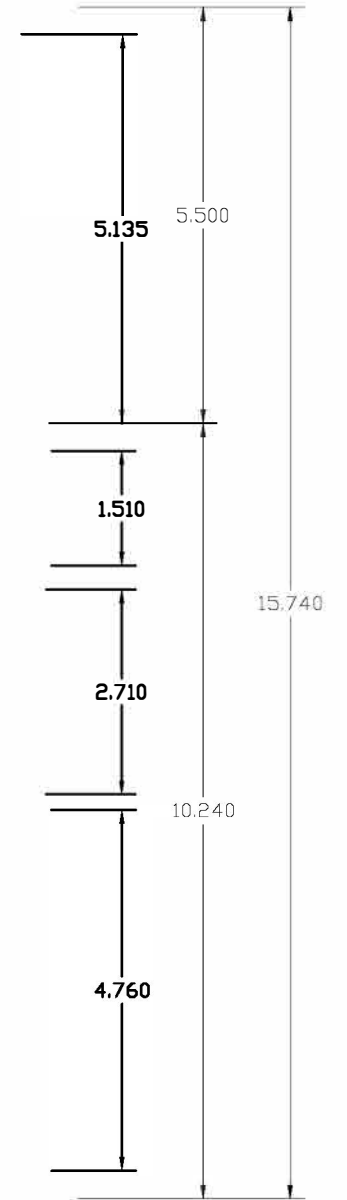
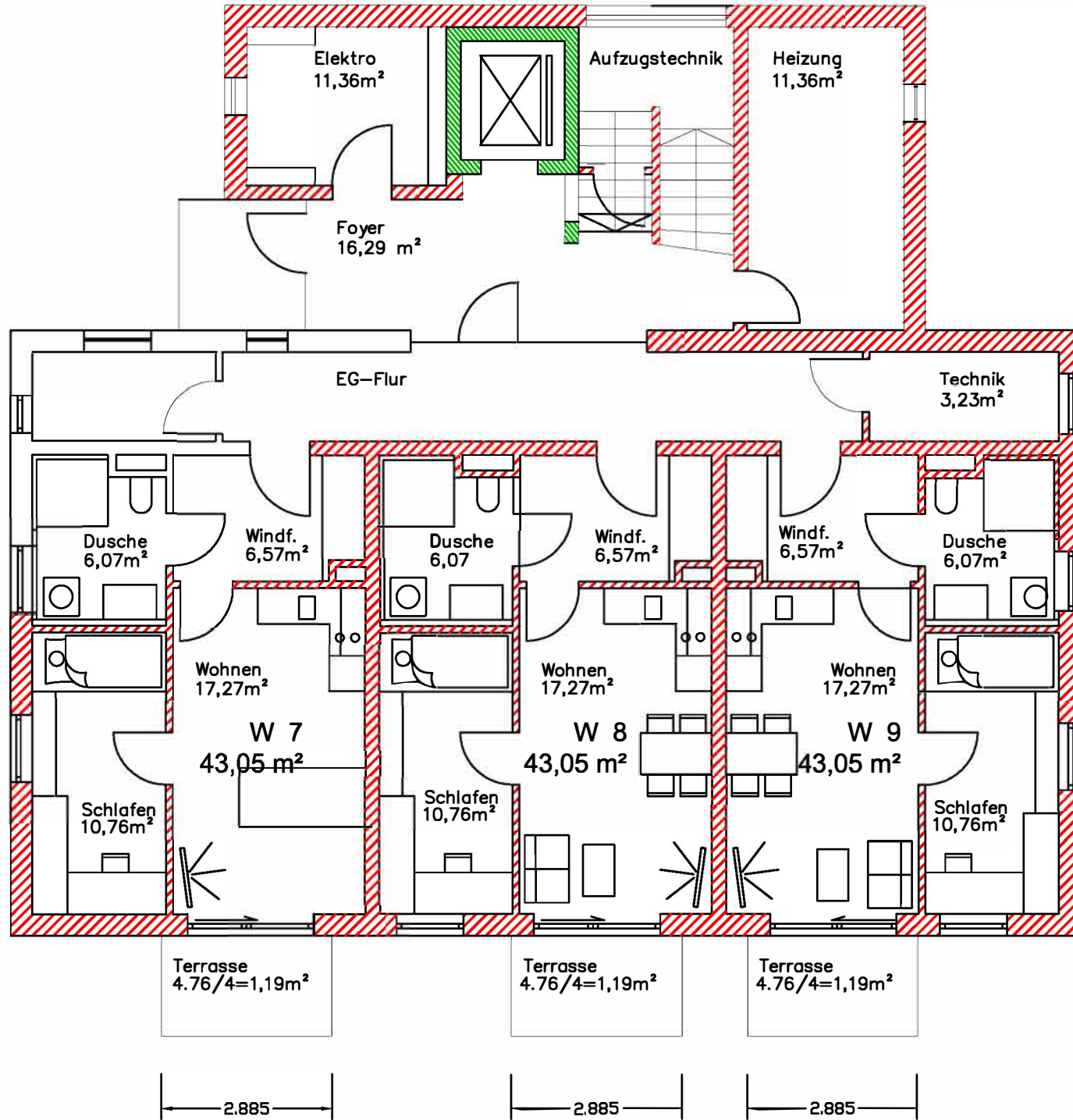
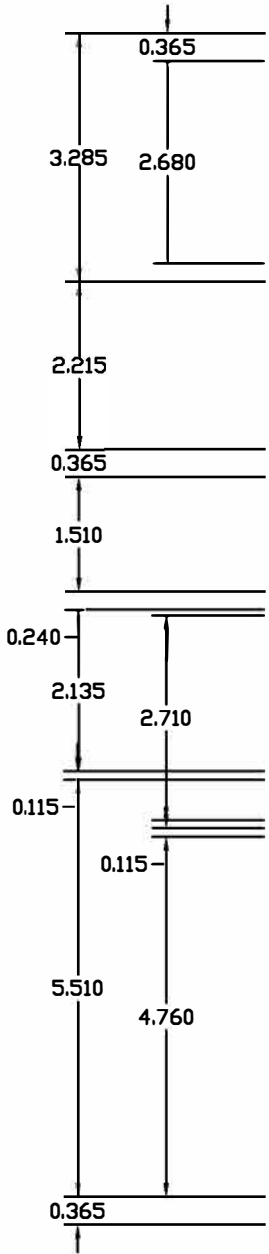
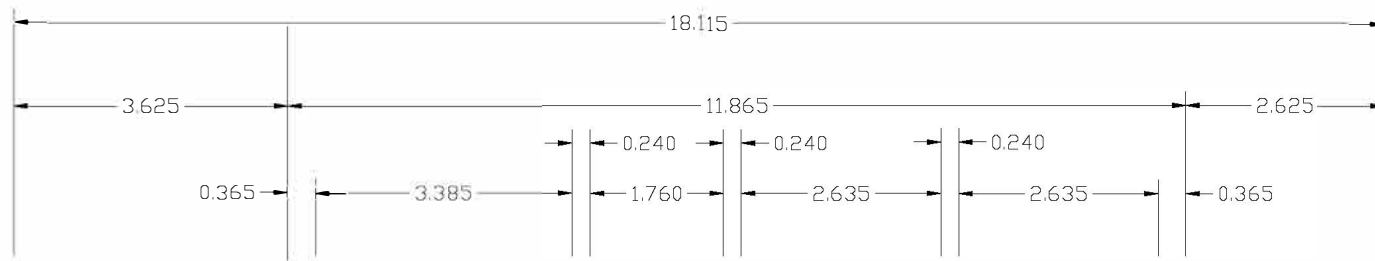

# OG

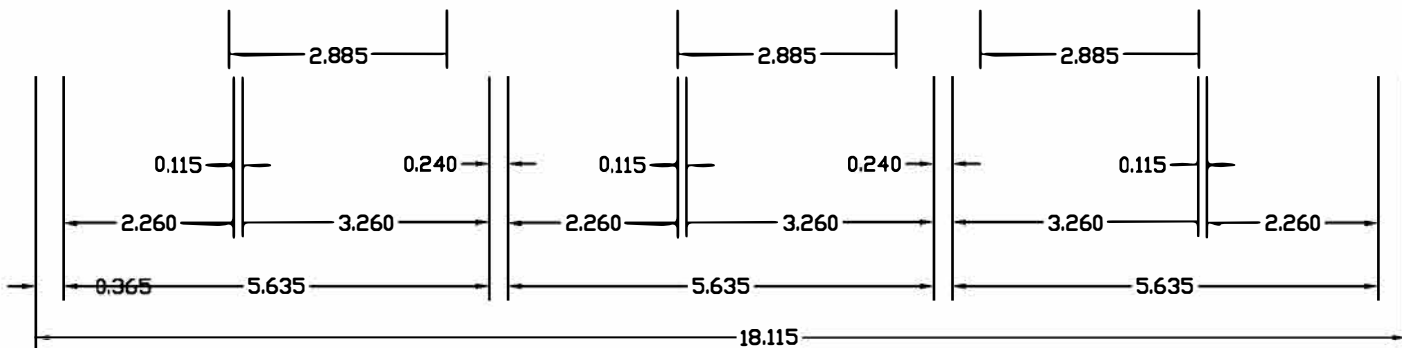
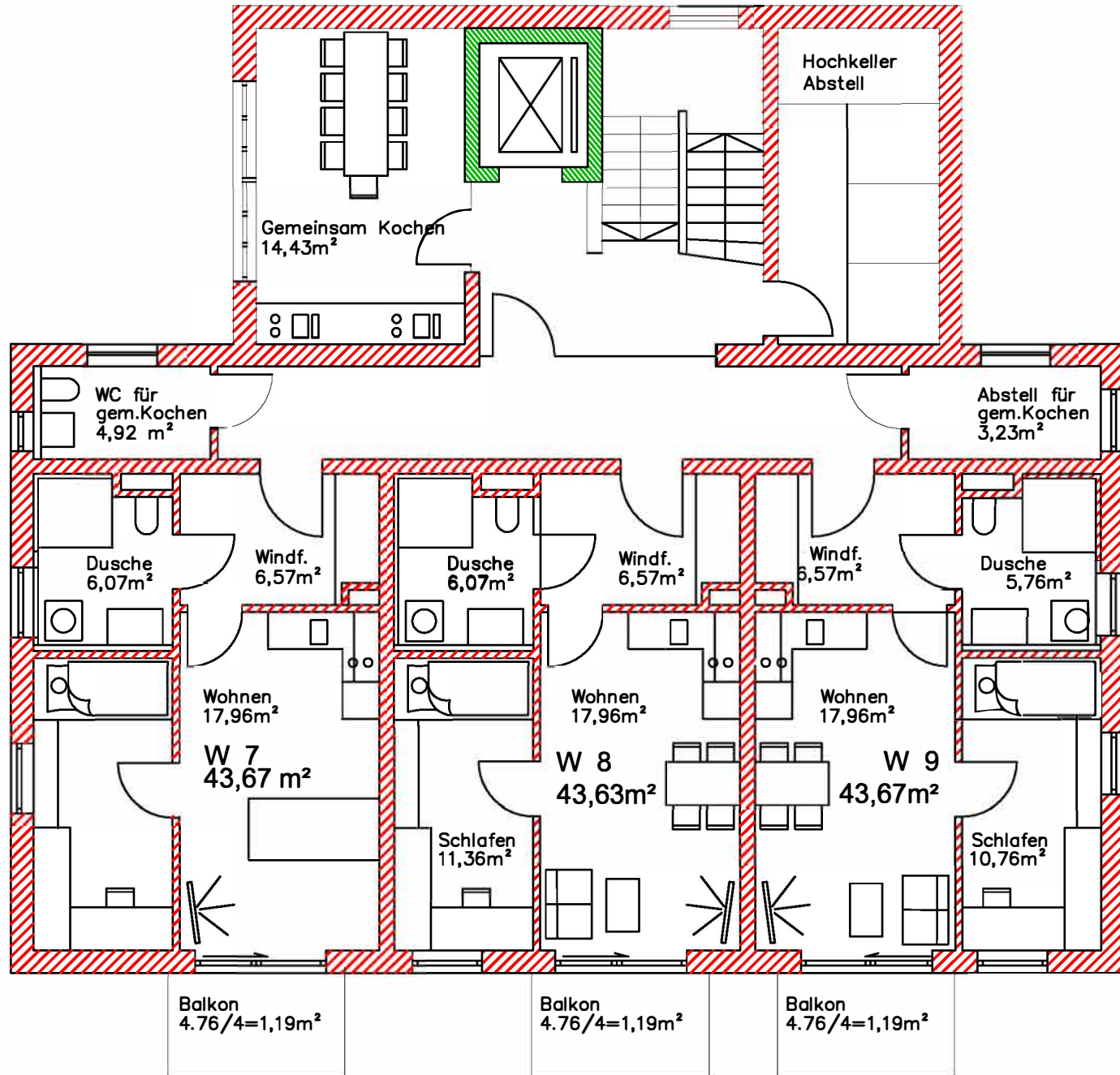
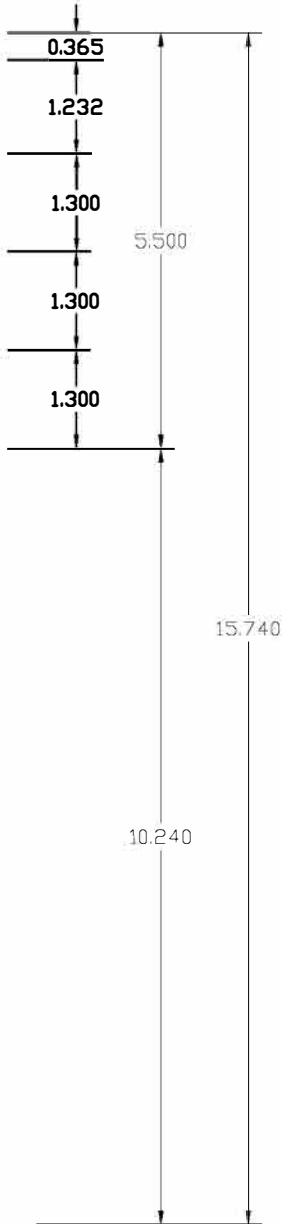
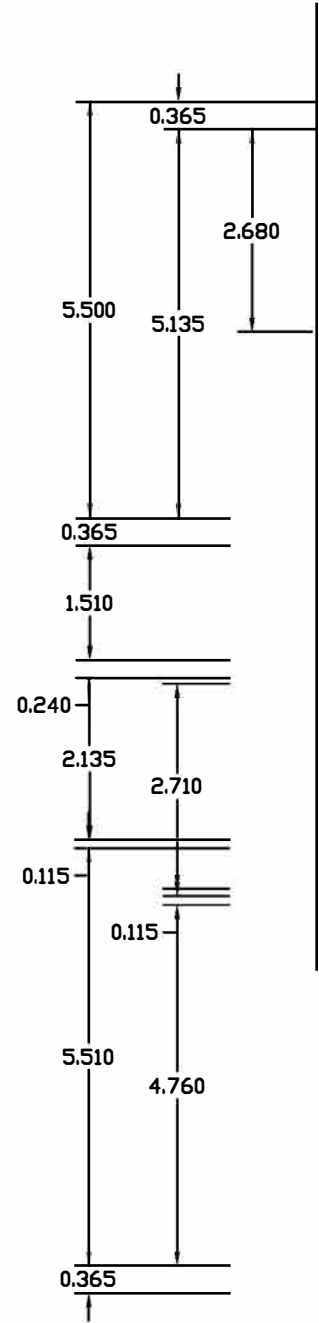
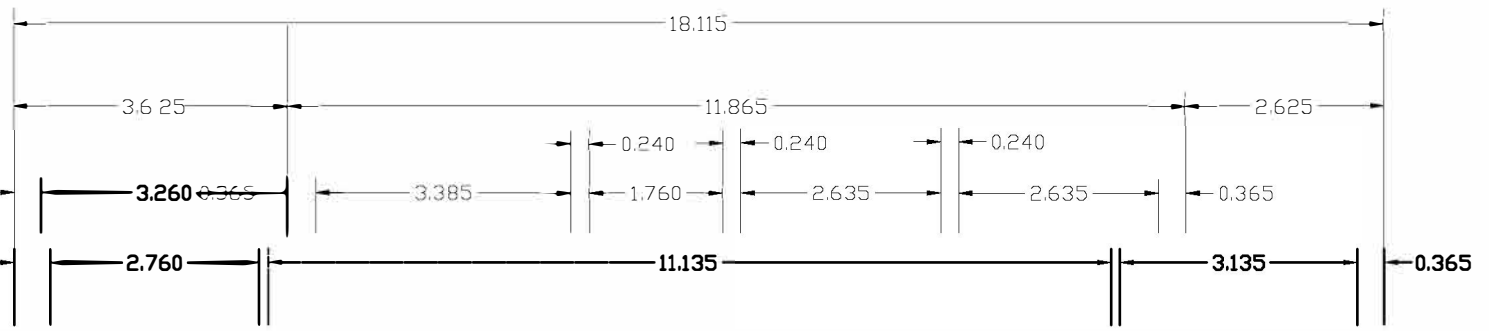

# DG

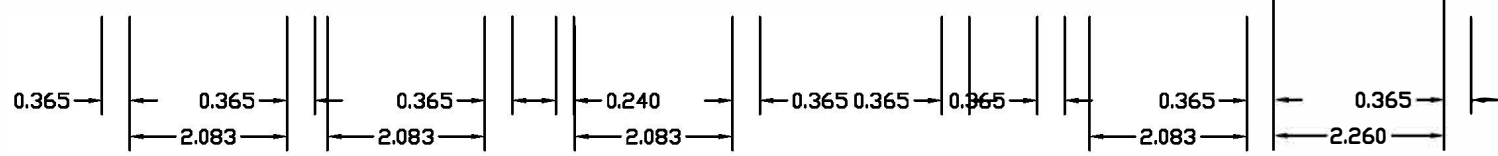
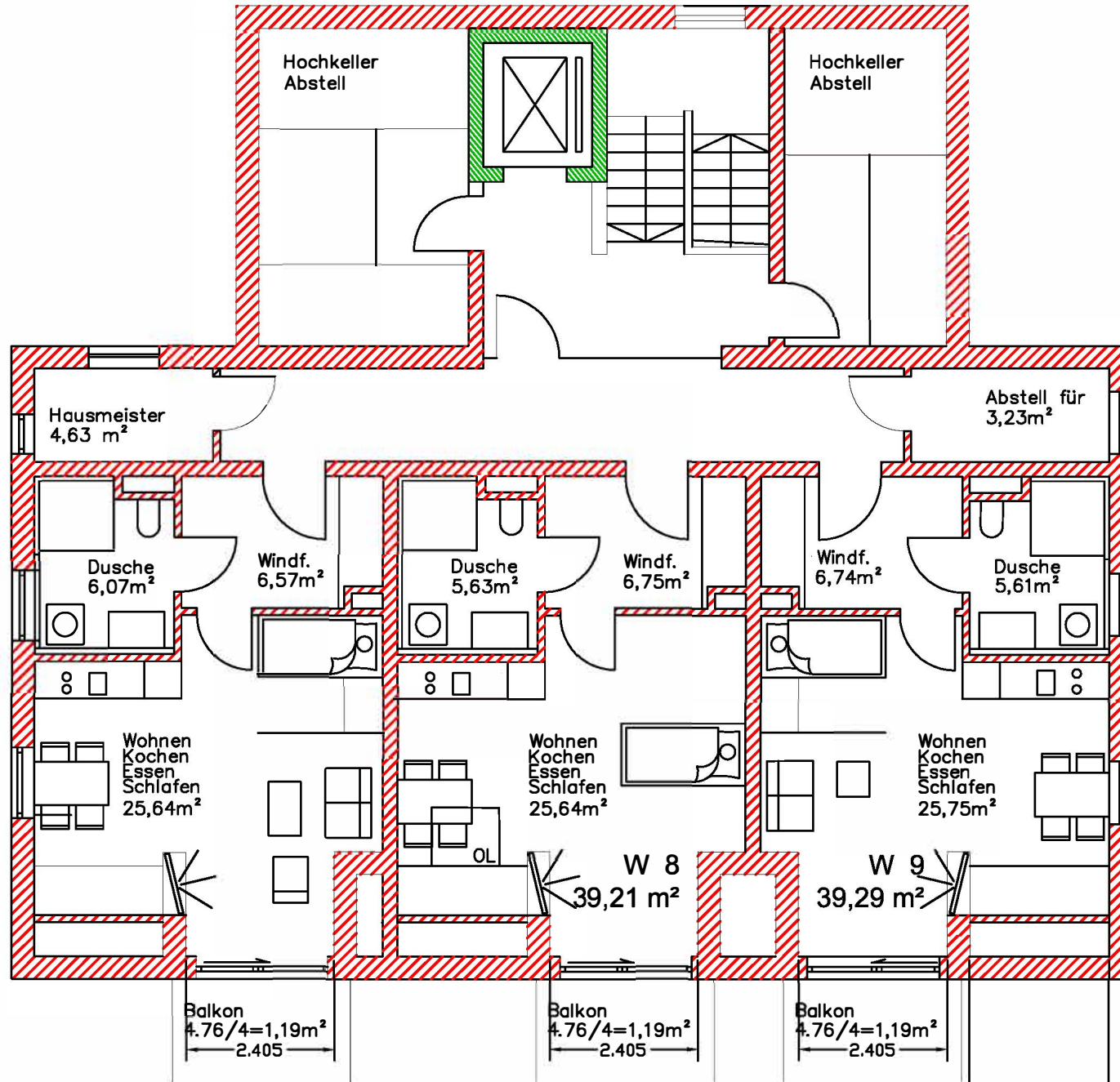
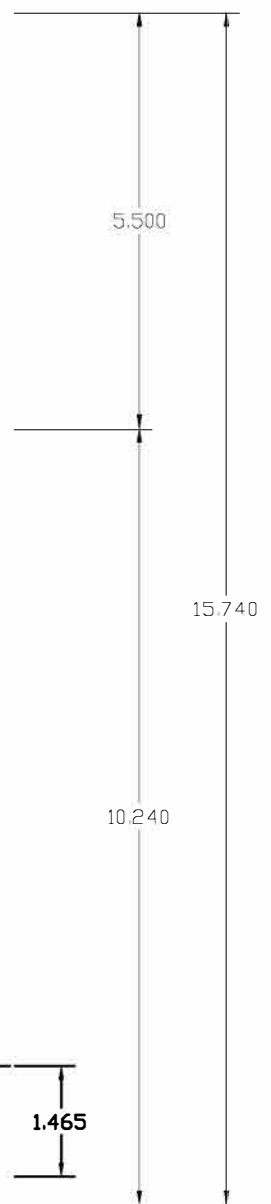
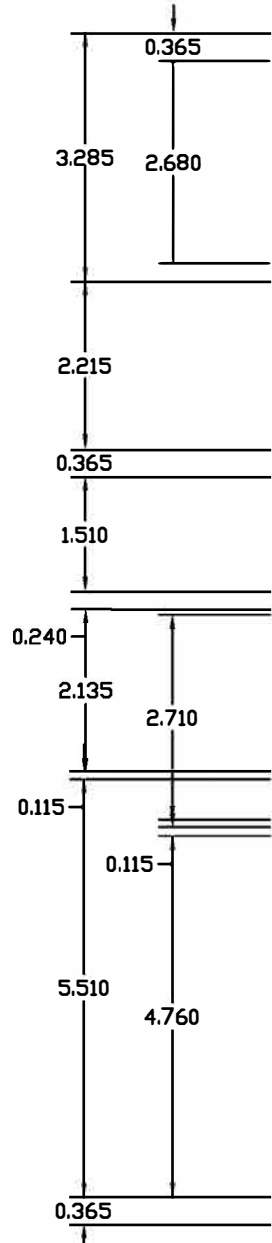
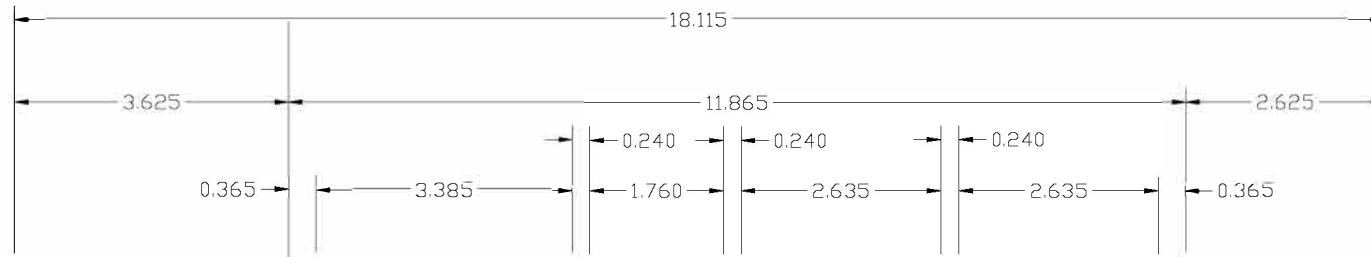

STAN